

# SONTH

# 武汉尚斯机电有限公司

# Sonth (HK) Industrial Co.,Ltd

## SG95-555: dc spur gear motor



### Description

- 1.Diameter: 95mm
- 2.Voltage: 24V (6~24V)
- 3.Input speed: 6000rpm (3000~18000rpm)
- 4.Reduction ratio: 1/36,1/94,1/149,1/211,1/394...
- 5.Output speed: 5~500rpm
- 6.Rated torque: 5~50Kg.cm
- 7.Can match encoder
- 8.Specs can be customized for you

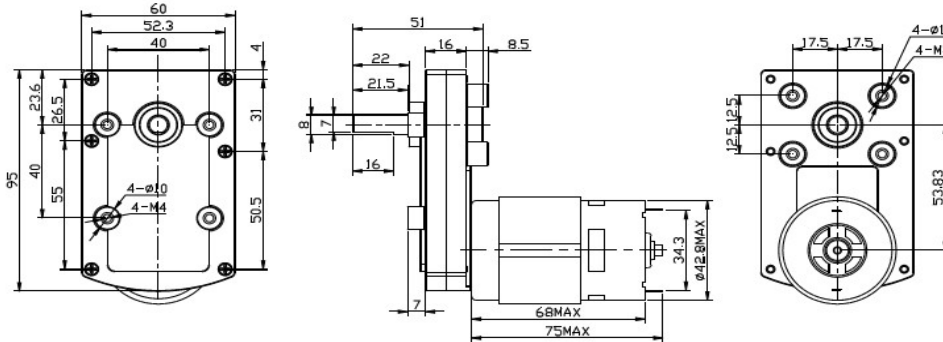

Reduction Ratio	Gearbox Length L= mm	No load Speed/rpm	Voltage 24V, Input 6000rpm (6V,12V,24V)				Stall	
			At load Speed/rpm	At load Current/A	At load Torque/Kg.cm	At load Power/W	Current/A	Torque/Kg.cm
1/36	16	166	130	3	5	10	8	15
1/66	16	90	70	3	5	10	8	15
1/94	16	60	48	3	5	10	8	15
1/149	16	40	32	3	30	10	8	80
1/196	16	30	24	3	30	10	8	80
1/211	16	28	22	3	30	10	8	80
1/277	16	22	17	3	30	10	8	80
1/394	16	15	12	3	30	10	8	80
1/624	16	9	7	3	50	10	8	150
1/830	16	7	5	3	50	10	8	150
1/1166	16	5	4	3	50	10	8	150

**Tel:** +86-27-87153161

**Fax:** +86-27-51893787

**Address:** 26th Floor,Block A,LongAn GangHui City,  
MinZu Road,Optical Vally,WuHan,HuBei,China

**Email:** cassy@sonth-industrial.com

**Web:** www.sonth-industrial.com; www.sonth123.com