

SG24PM: dc stepper gear motor

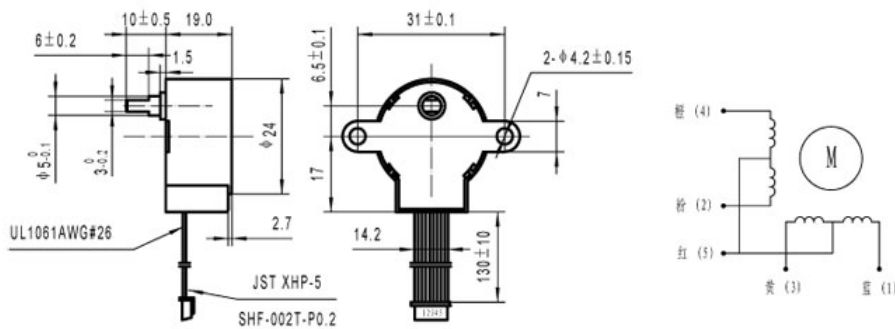

Description

- 1.Size: 24*19mm
- 2.Voltage: 12V (5~12V)
- 3.Step angle: 5.625°
- 4.Reduction ratio: 1/16,1/64....
- 5.Specs can be customized for you



Reduction Ratio	Voltage V	Step Angle		Resistance Ω	Torque	
		degree	Phase		Pull-in/g.cm	Pull-out/g.cm
1/16	5	5.625°/16	1-2	70	250	500
1/64	12	5.625°/64	1-2	200	250	500

TEL:+86-755-89480927
 FAX:+86-755-88366423
 Web: www.sonth123.com
 Msn: sonth123@hotmail.com