

SG35PM dc stepper gear motor

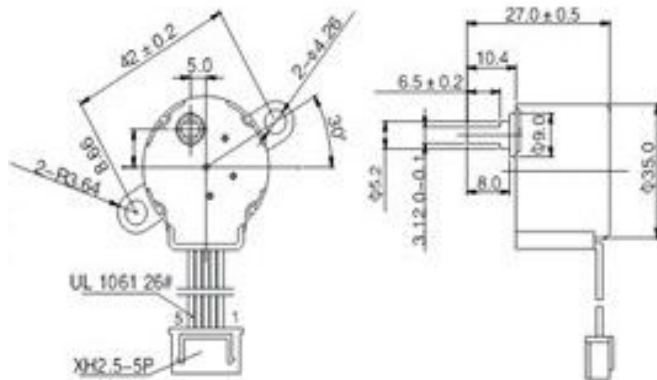

Description

- 1.Size: 35*16mm
- 2.Voltage: 12V (5-12V)
- 3.Step angle: 7.5°
- 4.Reduction ratio: 1/85
- 5.Specs can be customized for you



Reduction Ratio	Voltage V	Step Angle		Resistance Ω	Torque	
		degree	Phase		Pull-in/g.cm	Pull-out/g.cm
1/85	12	7.5°/85	4	200	650	1200

TEL:+86-755-89480927
 FAX:+86-755-88366423
 Web: www.sonth123.com
 Msn: sonth123@hotmail.com