

S35PM: dc stepper motor

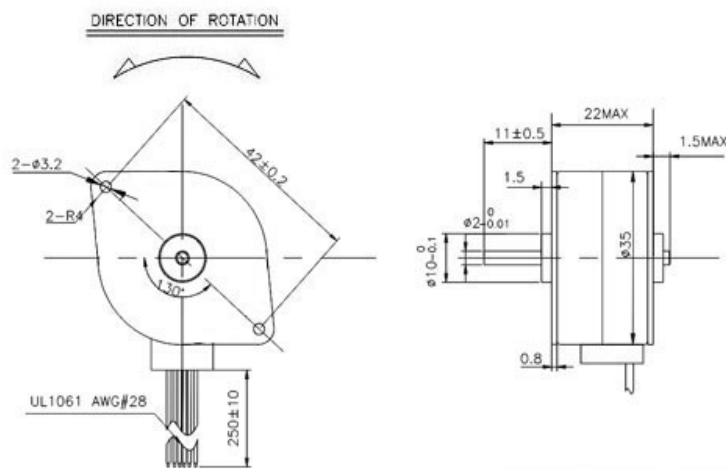

Description

- 1.Size: 35*22 mm
- 2.Voltage: 24V
- 3.Step angle: 7.5°
- 4.Phase: 2-2
- 5.Specs can be customized for you



UNIT: MILLIMETERS WEIGHT: 84 g(APPROX)

Voltage V	Step Angle		Starting/pps	Max Frequency			Torque	
	degree	Phase		Response/pps	Resistance/Ω	Pull-in/g.cm	Pull-out /g.cm	
24	7.5°	2-2	-	-	120	125	550	

TEL:+86-755-89480927

FAX:+86-755-88366423

Web: www.sonth123.com

Msn: sonth123@hotmail.com