

### SF-030: dc metal brushed motor

#### Description



- 1.Size: 15.5\*12\*18.6 mm
- 2.Voltage: 6V
- 3.Speed: 10500 rpm
- 4.Rated torque: 4.2g.cm
- 5.Specs can be customized for you

#### DIRECTION OF ROTATION

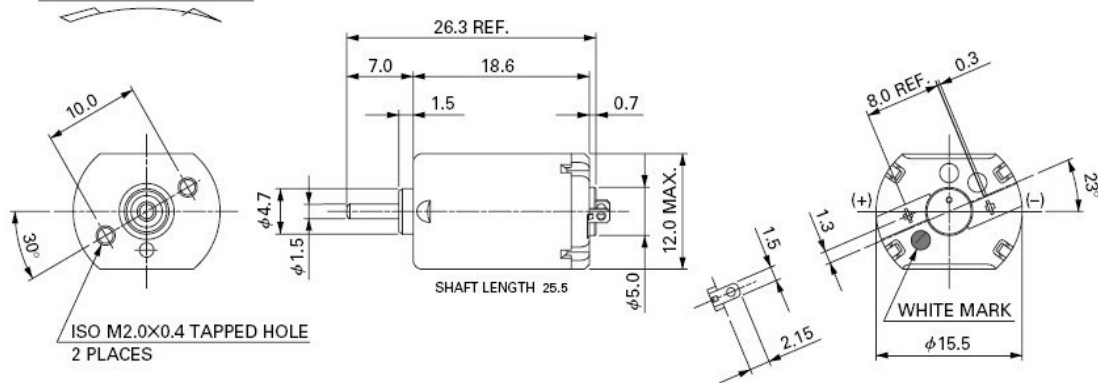

Voltage V	No load		At load				Stall	
	Speed/rpm	Current/A	Speed/rpm	Current/A	Torque/g.cm	Power/W	Current/A	Torque/g.cm
6	10500	0.04	8000	0.13	4.3	0.35	0.43	19
2.5	4800	0.035	3400	0.094	2.3	0.08	0.25	9

TEL:+86-755-89480927  
 FAX:+86-755-88366423  
 Web: [www.sonth123.com](http://www.sonth123.com)  
 Msn: [sonth123@hotmail.com](mailto:sonth123@hotmail.com)